

## Automobile Spray Painting Line Conveyor Chains

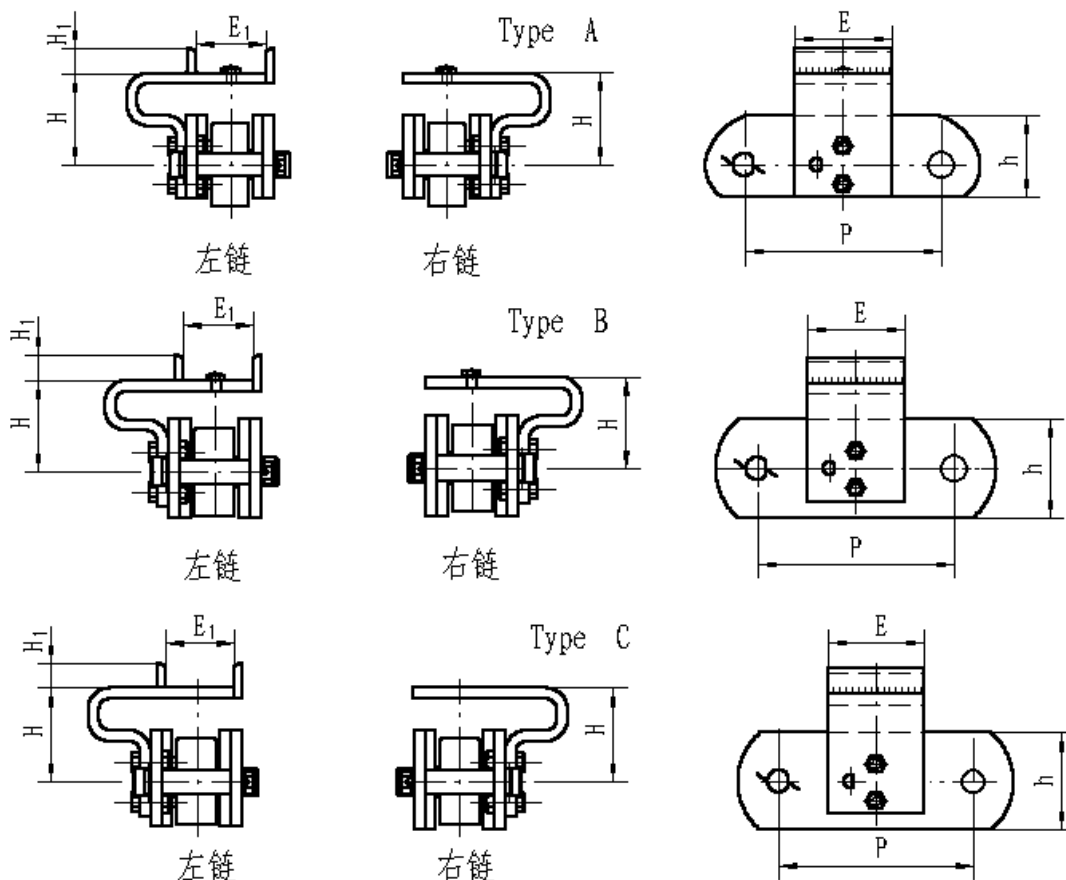

Chain No.	P mm	E mm	$E_1$ mm	h mm	H mm	$H_1$ mm	Type
P152.4-A (左)	152.4	76	65	63.5	77.1	20	A
P152.4-A (右)	152.4	76	/	63.5	77.1	/	A
P152.4A-N <sub>1</sub> (左)	152.4	76	55	63.5	77.1	20	A
P152.4A-N <sub>1</sub> 漬(右)	152.4	76	/	63.5	77.1	/	A
P152.4-B (左)	152.4	76	65	63.5	77.1	20	A
P152.4-B (右)	152.4	76	/	63.5	77.1	/	A
P152.4B-N <sub>1</sub> 漬(左)	152.4	76	55	76.2	76.7	20	B
P152.4B-N <sub>1</sub> 漬(右)	152.4	76	/	76.2	76.7	/	B
P152.4B-N <sub>2</sub> (左)	152.4	76	55	76.2	76.7	20	C
P152.4B-N <sub>2</sub> (右)	152.4	76	/	76.2	76.7	/	C
P100-C (左)	100	70	55	72	72	20	B
P100-C (右)	100	70	/	72	72	/	B

$Q_{\min}$  KN = Ultimate tensile strength

## Automobile Spray Painting Line Conveyor Chains

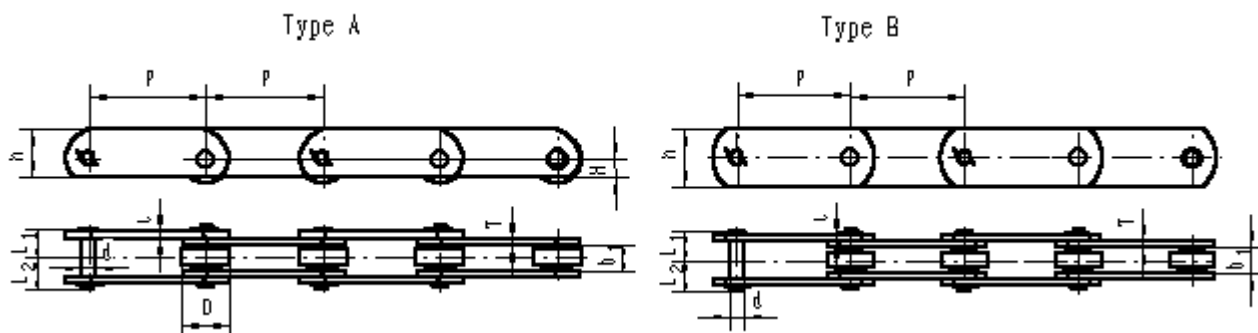

Chain No.	P mm	b <sub>1</sub> (min) mm	D( max) mm	d	L <sub>1</sub>	L <sub>2</sub>	h	H	t/T	Q(min) kN	q kg/m	Type
				mm	mm	mm	mm	mm	mm			
P152.4	152.4	35	63.5	17.6	39.4	44.1	63.5	25	8	300	15.7	A
P152.4-N1	152.4	35	63.5	17.6	39.4	44.1	76.2	/	8	300	18.29	B
P100	100	35	60	17.6	39.4	44.1	72	/	8	350	21.14	B

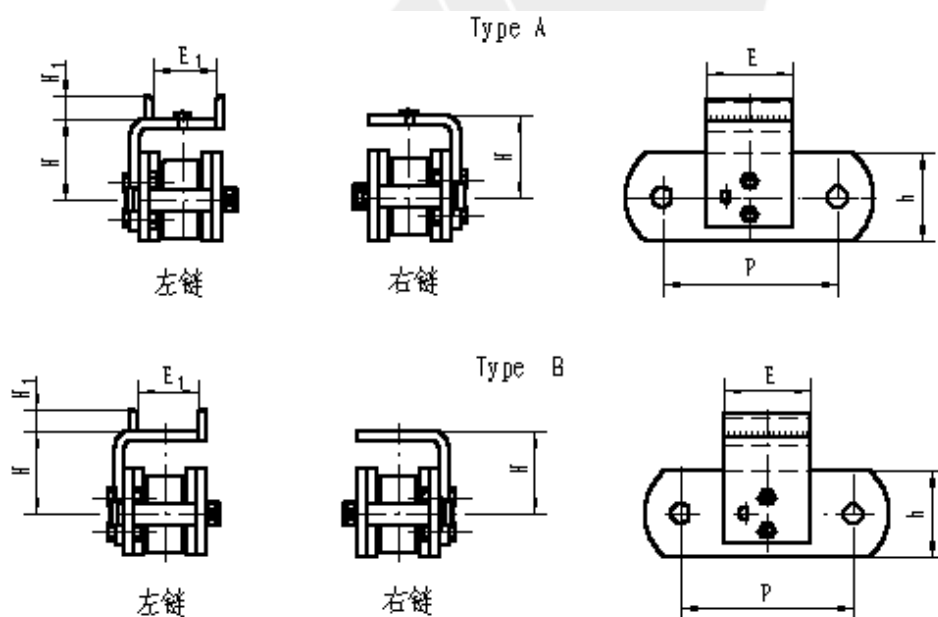

Chain No.	P mm	E mm	E <sub>1</sub> mm	h mm	H mm	H <sub>1</sub> mm	Type
P100-A (左)	100	70	55	72	78	20	A
P100-A (右)	100	70	/	72	78	/	A
P100-B (左)	100	70	55	72	78	20	B
P100-B (右)	100	70	/	72	78	/	B

Q<sub>min</sub> KN = Ultimate tensile strength