

Water Dispose Chain

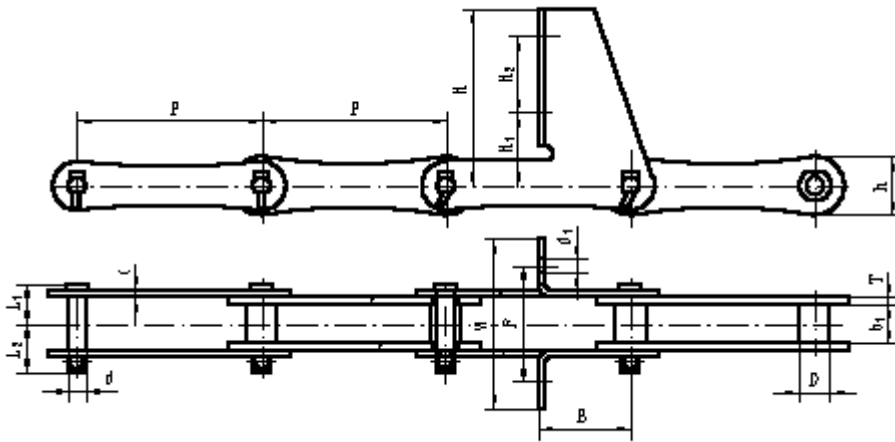

F	W	B	d ₁	H ₁	H ₂	H
95.3	139.7	76.2	11.1	60.3	114.3	200

Chain No.	P mm	b ₁ (min) mm	D(max) mm						Q(min) kN
				d mm	L ₁ mm	L ₂ mm	h mm	T mm	
SS700-F228	152.4	30	26	14.5	32.9	39.3	48	6	146.6

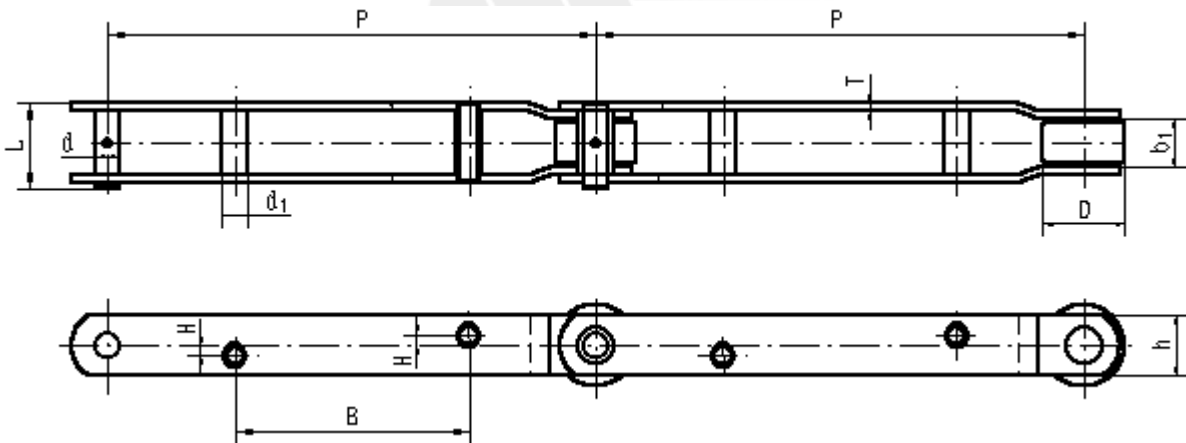

Chain No.	P mm	b ₁ (min) mm	D(max) mm	d ₁ mm							Q(min) kN	q kg/m
					d mm	L mm	h mm	T mm	B mm	H mm		
WT24	609.6	39.4	101.6	32	30.73	84.3	76.2	9.52	292.1	12.7	360	16.9

Q_{min} KN = Ultimate tensile strength